

The old sign in the bottom of the Stormglass or Galileiglass to be repaired must be removed first. Press carefully on the side of the sign with a screwdriver to make the sign tilt so you can get hold of the opposite side of the sign and remove it.

Now you can remove old foam supports, glue residue and ampoule.

Insert one of the foam supports (2) - the shortest if they have different sizes - in the top of the house.

Place a little glue as shown (arrow 3).

Use a silicone based clear glue or similar.

Insert the ampoule (4) with the flat surface upwards*.

Insert the other foam support (5). Stuff it well so it is min. 3-4mm below the bottom edge of the housing all the way round.

Glue all the way round making a junction between housing and foam (arrows 6).

Finally the sign (7) is placed carefully on the glue so it's lying 1-2mm below the bottom edge of the housing.

Leave the Stormglass or Galileiglass up side down to dry until next day.

Happy Cruising!
Delite ApS

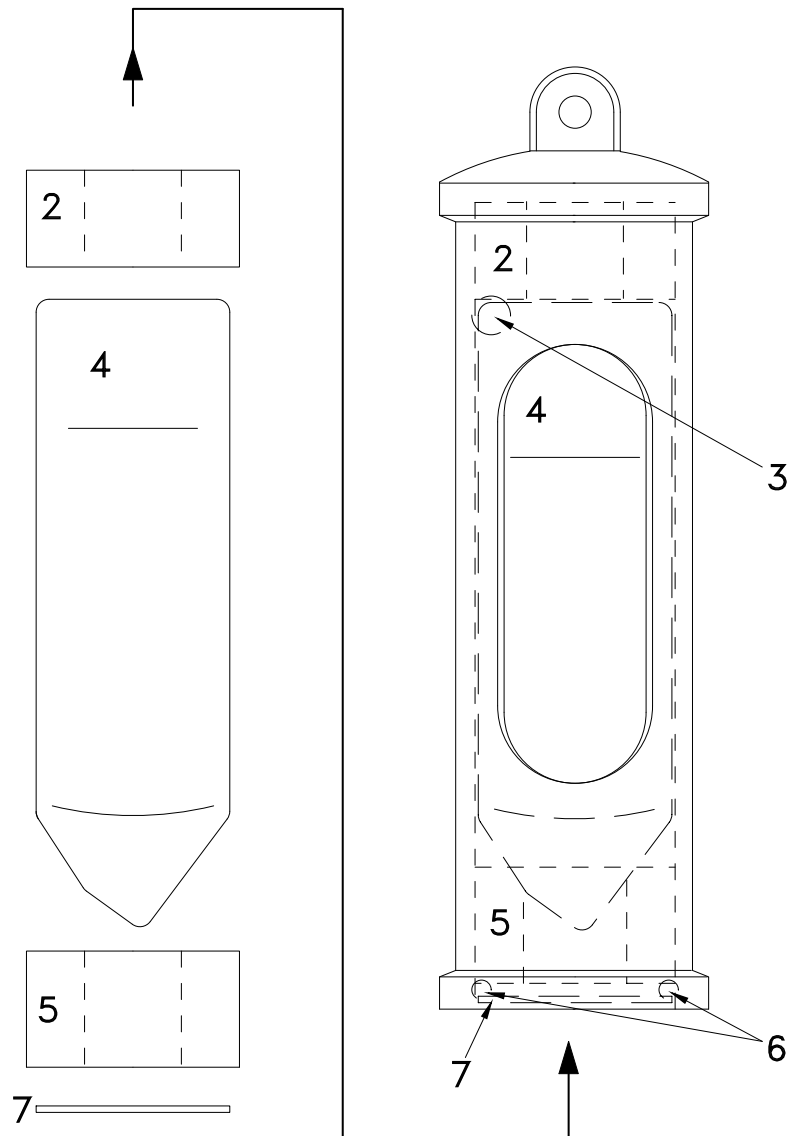

*) The Galileiglass ampoule must be oriented so the highest temperature marking is in the top position when the galileiglass is standing upright.